

# CITY PARK SIGNAGE

Bozeman, Montana

**Owner** City of Bozeman Parks  
Attn: Thom White  
415 N. Bozeman Ave  
Bozeman Montana, 59771

**Architect** Intrinsic Architecture, INC.  
111 North Tracy Avenue  
Bozeman Montana, 59715  
Ph. (406) 582-8988 Fx. (406) 582-8911  
www.intrinsicarchitecture.com

JUNE 11, 2014 ISSUED FOR: PRICING INFORMATION

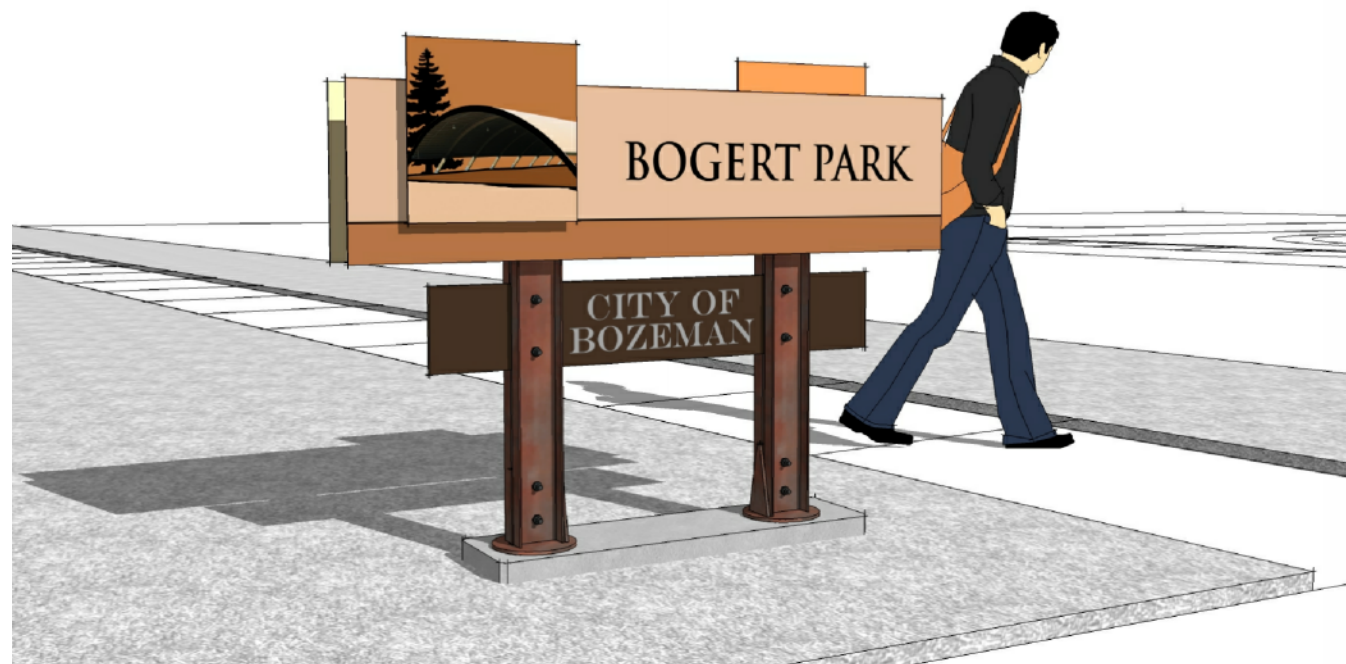

## DRAWING INDEX

### ARCHITECTURAL

A0.1	COVER SHEET
A3.1	ELEVATION AND SECTIONS
A5.1	SIGN DETAILS

**INTRINSIK**  
ARCHITECTURE  
INCORPORATED  
111 N. Tracy Ave. • Bozeman, Montana • 59715 • Ph: 406.582.8988 • Fax: 406.582.8911

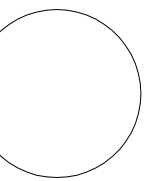

Bozeman, MT  
address

**CPS**  
City Parks Signage  
project code

**A0.1**  
COVER SHEET  
CD  
sheet  
06.11.2014

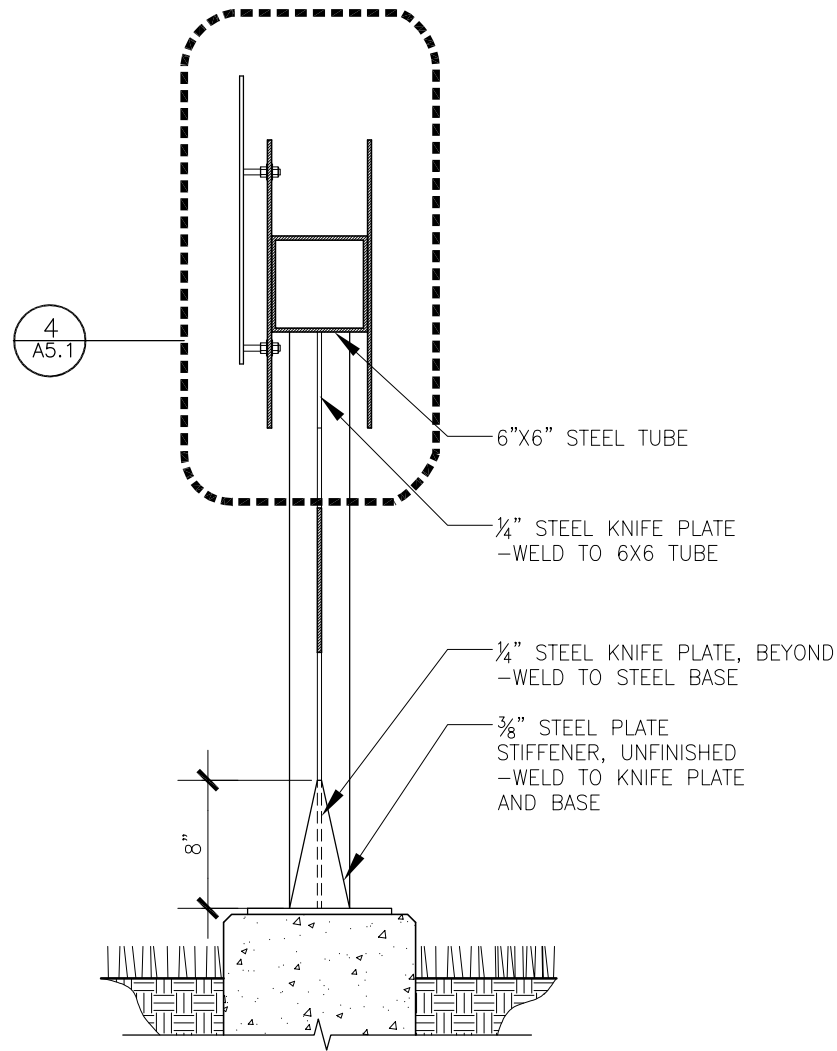

**2** SECTION  
**A3.1** 1"=1'-0"

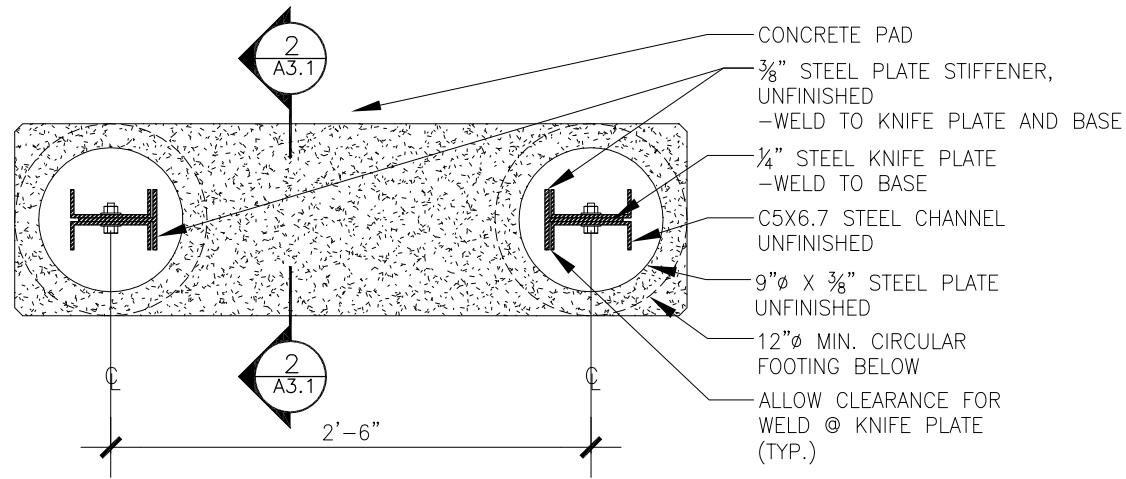

**3** PLAN SECTION  
**A3.1** 1"=1'-0"

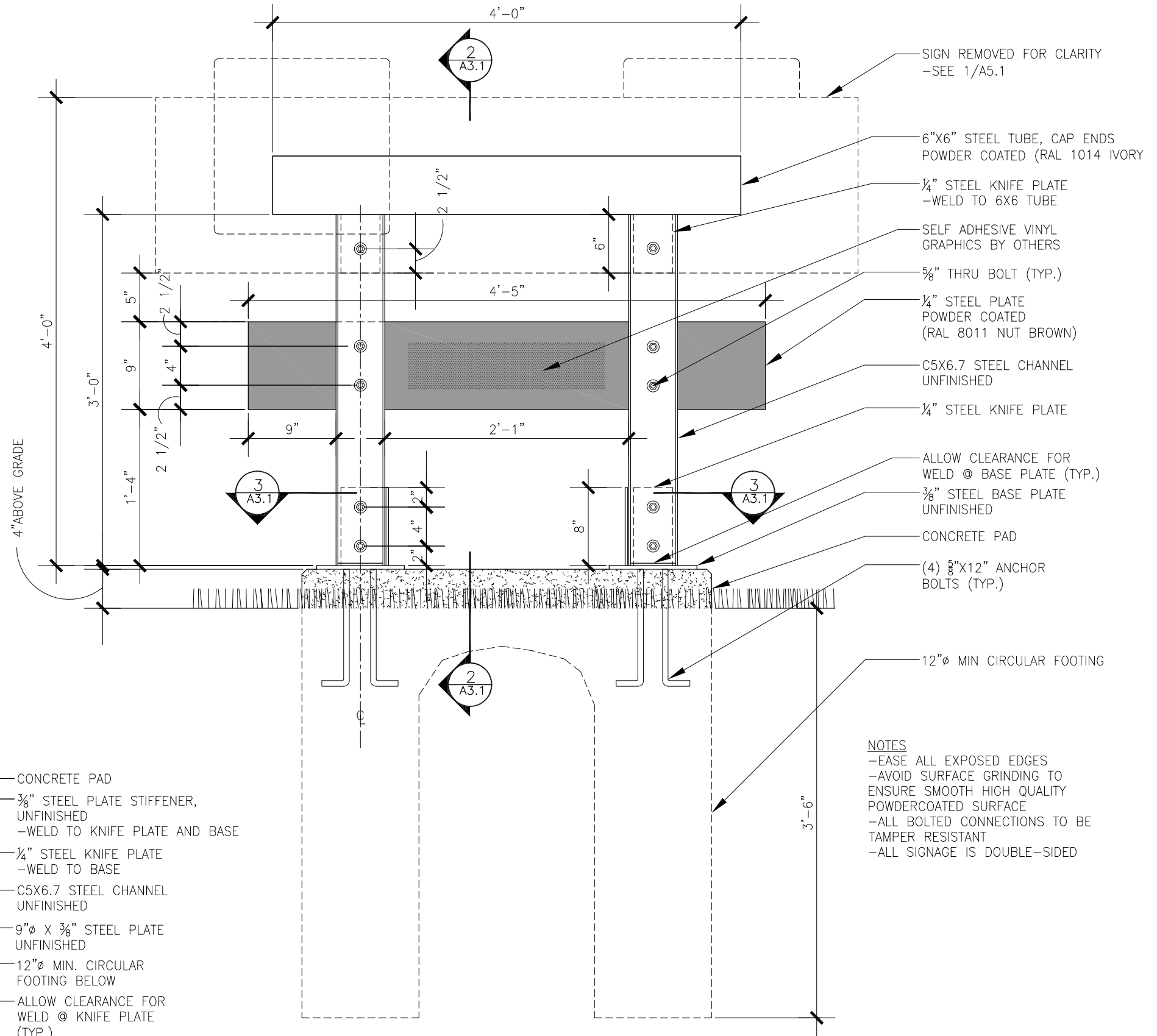

**1** FRONT ELEVATION  
**A3.1** 1"=1'-0"

**NOTES**  
 -EASE ALL EXPOSED EDGES  
 -AVOID SURFACE GRINDING TO ENSURE SMOOTH HIGH QUALITY POWDERCOATED SURFACE  
 -ALL BOLTED CONNECTIONS TO BE TAMPER RESISTANT  
 -ALL SIGNAGE IS DOUBLE-SIDED

**intrin:nsik**  
 ARCHITECTURE  
 INCORPORATED  
 111 N. Tracy Ave. • Bozeman, Montana • 59715 • Ph: 406.582.8988 • Fax: 406.582.8911

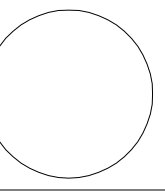

Bozeman, MT address

**CPS**  
 City Parks Signage project code

**A3.1**  
 ELEVATION & SECTIONS  
 CD sheet

06.11.2014

© 2014 INTRINSIK

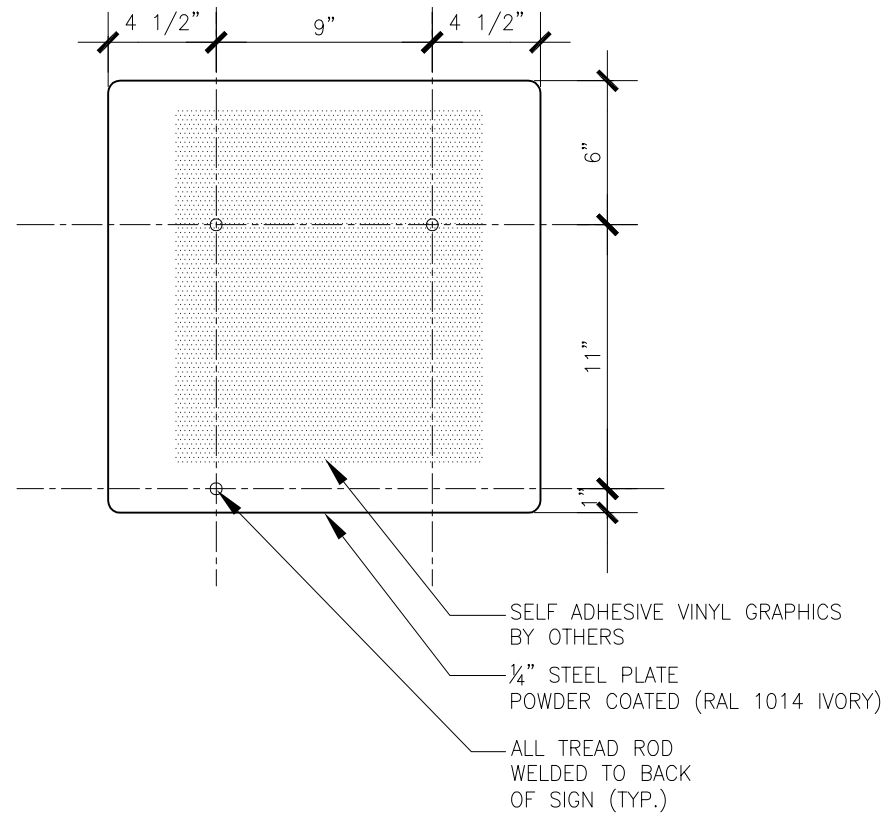

**2** SIGN ELEVATION  
**A5.1** 1 1/2"=1'-0"

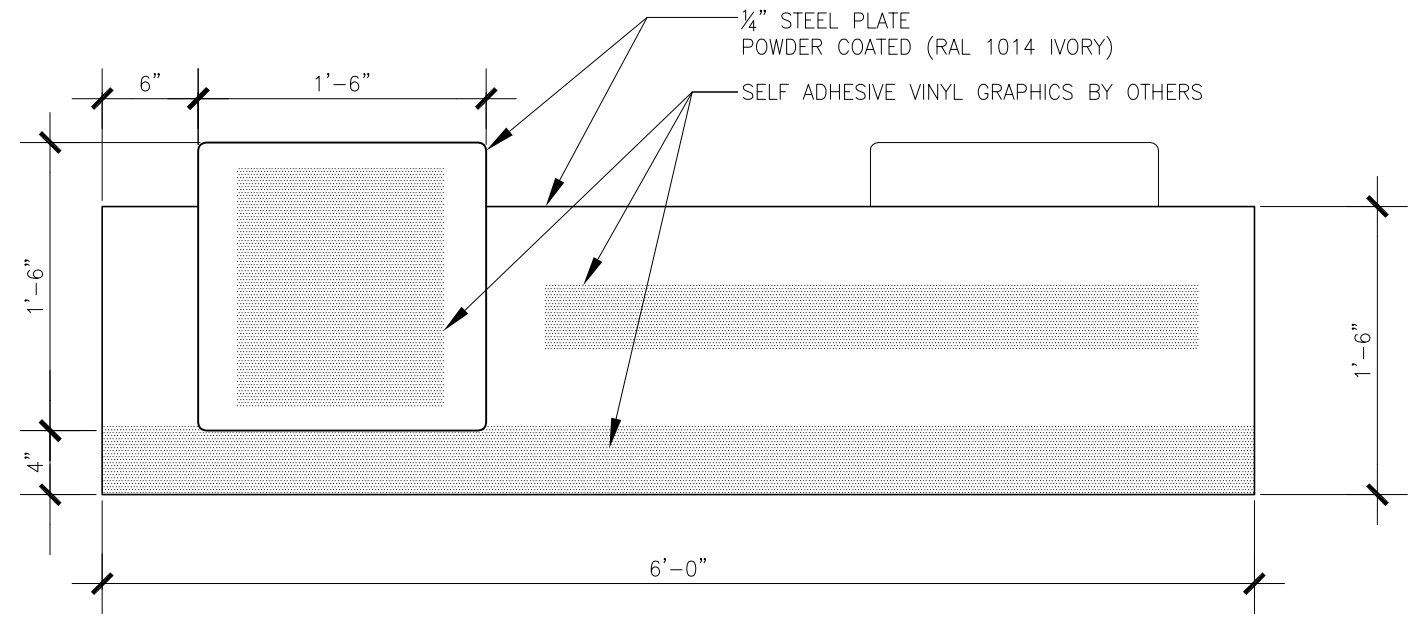

**1** SIGN ELEVATION  
**A5.1** 1"=1'-0"

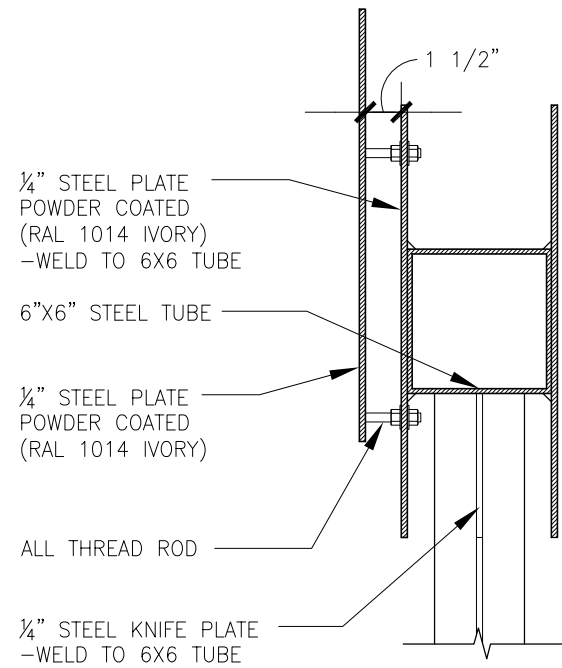

**4** SIGN DETAIL  
**A5.1** 1 1/2"=1'-0"

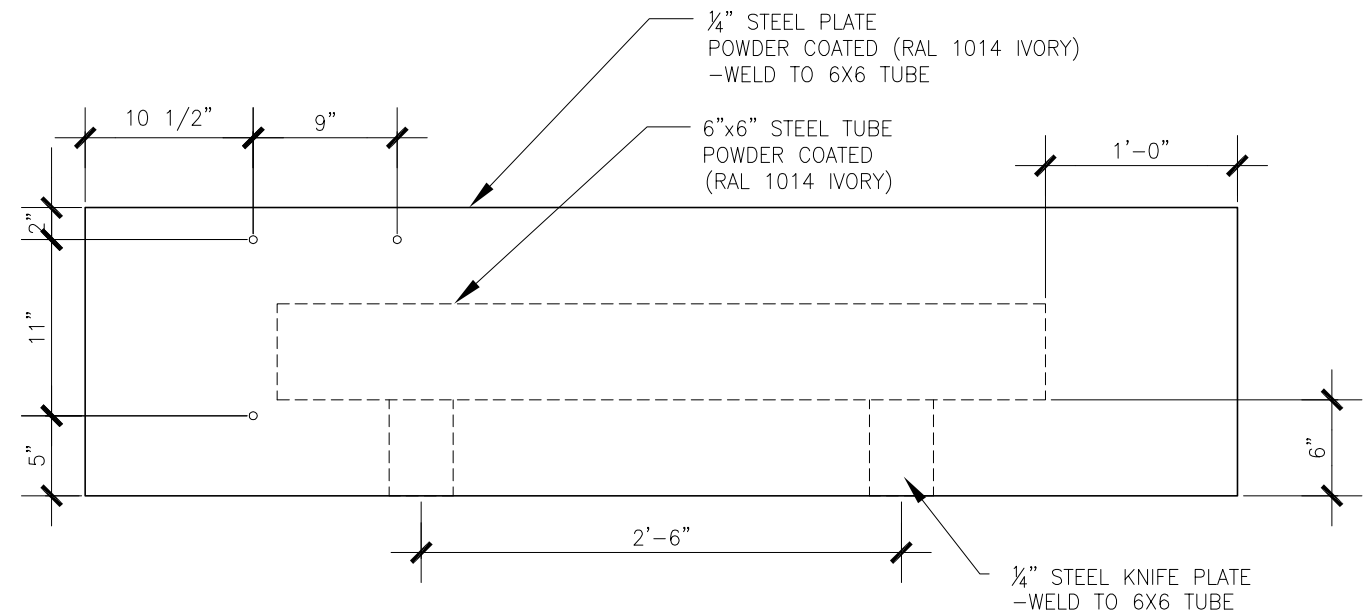

**3** SIGN DETAIL  
**A5.1** 1"=1'-0"

